



EXTRUDED FENDERS

Extruded Fenders are simple rubber profiles, usually attached with bolts to the structure.* Extrusions can be made in virtually any length, then cut and drilled to suit each application. Pre-curved sections and special sizes are available on request.

- ▶ Jetties and wharves for small craft
- ▶ Pontoon protection
- ▶ Inland waterways
- ▶ General purpose fendering
- ▶ Tugs and workboats

* ShibataFenderTeam provides standard sizes for each profile with the availability to manufacture acc. to customer specific needs.
All extruded fender can be installed in a variety of methods.

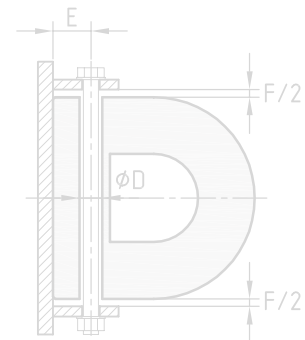

GENERIC PERFORMANCE CURVE EXTRUDED FENDERS

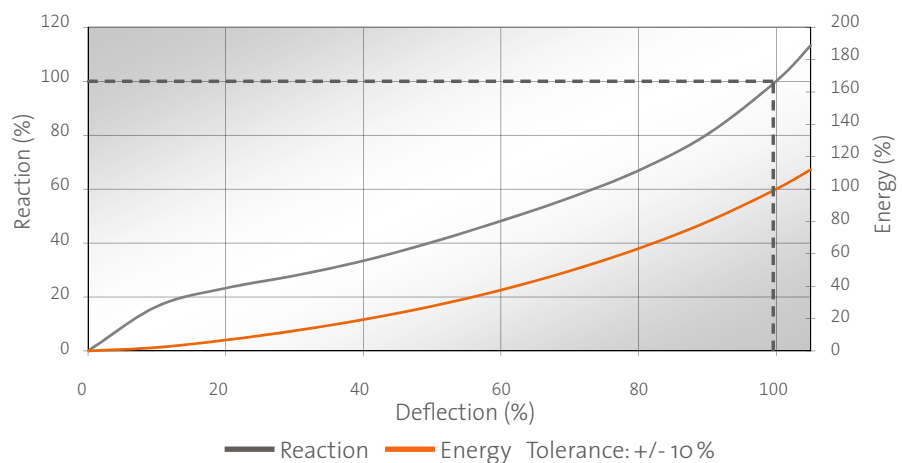



DD FENDERS

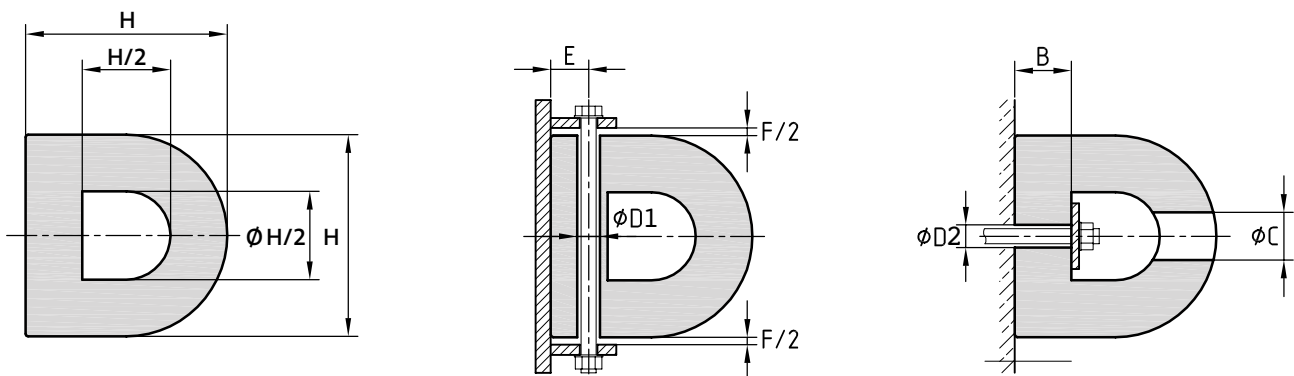

DD FENDER DIMENSIONS

H [mm]	B [mm]	C [mm]	D1 [mm]	D2 [mm]	E [mm]	F [mm]	G* [mm]	ED* [mm]	Flat Bar [mm]	Anchors	Weight / m [kg]
100 x 100	25.0	30	18	24	25	10	200~300	90~130	40 x 5	M 12	8.3
150 x 150	37.5	40	24	32	30	12	250~350	110~150	60 x 8	M 16	18.0
200 x 200	50.0	50	30	40	45	15	300~400	130~180	80 x 10	M 20	32.0
250 x 250	62.5	60	36	48	45	20	350~450	140~200	90 x 12	M 24	50.0
300 x 300	75.0	60	36	48	60	25	350~450	140~200	110 x 12	M 24	72.0
350 x 350	87.5	75	45	60	70	25	350~450	140~200	130 x 15	M 30	103.6
380 x 380	95.0	75	45	60	80	30	350~450	140~200	140 x 15	M 30	122.1
400 x 400	100.0	75	45	60	80	30	350~450	140~200	150 x 15	M 30	128.0
500 x 500	125.0	90	54	72	90	40	400~500	160~230	180 x 20	M 36	200.0

*Fixing Position see Page 69 acc. to ShibataFenderTeam standard manufacturing tolerances

DC FENDERS

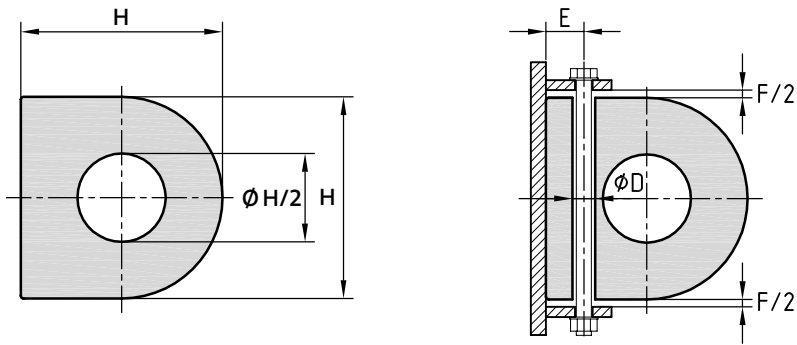

DC FENDER DIMENSIONS

H [mm]	D [mm]	E [mm]	F [mm]	G* [mm]	ED* [mm]	Anchors	Weight / m [kg]
100 x 100	18	25	10	200~300	90~130	M 12	9.9
150 x 150	24	30	12	250~350	110~150	M 16	20.0
200 x 200	30	45	15	300~400	130~180	M 20	37.4
250 x 250	36	50	20	350~450	140~200	M 24	57.2
300 x 300	36	60	25	350~450	140~200	M 24	81.3
350 x 350	45	70	25	350~450	140~200	M 30	109.5
400 x 400	45	80	30	350~450	140~200	M 30	142.0
500 x 500	54	90	40	400~500	150~230	M 36	208.0

*Fixing Position see Page 69 acc. to ShibataFenderTeam standard manufacturing tolerances

SD FENDERS

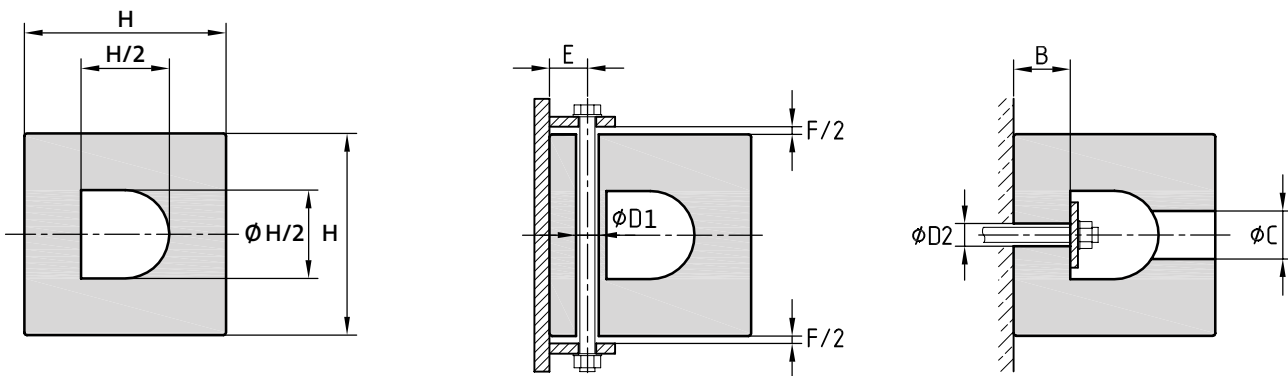

SD FENDER DIMENSIONS

H [mm]	B [mm]	C [mm]	D1 [mm]	D2 [mm]	E [mm]	F [mm]	G* [mm]	ED* [mm]	Flat Bar [mm]	Anchors	Weight / m [kg]
100 x 100	25.0	30	18	24	25	10	200~300	90~130	40 x 5	M 12	9.5
150 x 150	37.5	40	24	32	30	12	250~350	110~150	50 x 8	M 16	22.1
200 x 200	50.0	50	30	40	45	15	300~400	130~180	70 x 10	M 20	38.7
250 x 250	62.5	60	36	48	50	20	350~450	140~200	90 x 12	M 24	59.3
300 x 300	62.5	60	36	48	50	25	350~450	140~200	100 x 12	M 24	73.0
350 x 350	75.0	75	45	60	60	25	350~450	140~200	100 x 15	M 30	89.3
400 x 400	100.0	75	45	60	80	30	350~450	140~200	150 x 15	M 30	148.5
500 x 500	125.0	90	54	72	90	40	400~500	160~230	180 x 20	M 36	232.1

*Fixing Position see Page 69 acc. to ShibataFenderTeam standard manufacturing tolerances

SC FENDERS

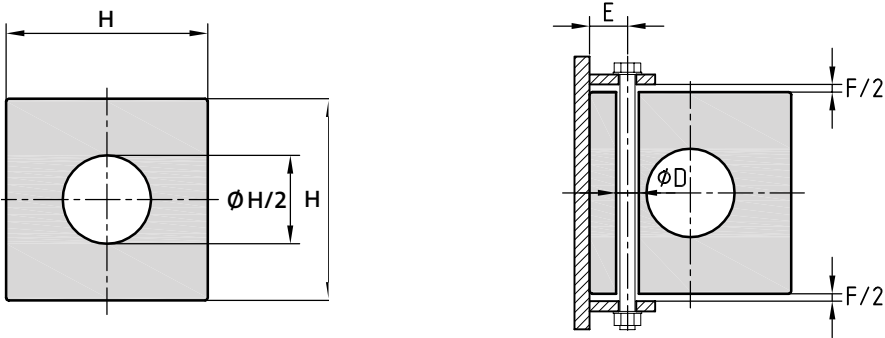

SC FENDER DIMENSIONS

H [mm]	D [mm]	E [mm]	F [mm]	G [mm]	ED [mm]	Anchors	Weight / m [kg]
100 x 100	18	25	10	200~300	90~130	M12	11,1
150 x 150	24	30	12	250~350	110~150	M16	22,9
200 x 200	30	45	15	300~400	130~180	M20	42,6
250 x 250	36	50	20	350~450	140~200	M24	65,3
300 x 300	36	60	25	350~450	140~200	M24	92,9
350 x 350	45	70	25	350~450	140~200	M30	117,6
400 x 400	45	80	30	350~450	140~200	M30	153,6
500 x 500	54	90	40	400~500	150~230	M36	240,1

FIXING POSITION FOR ALL TYPES

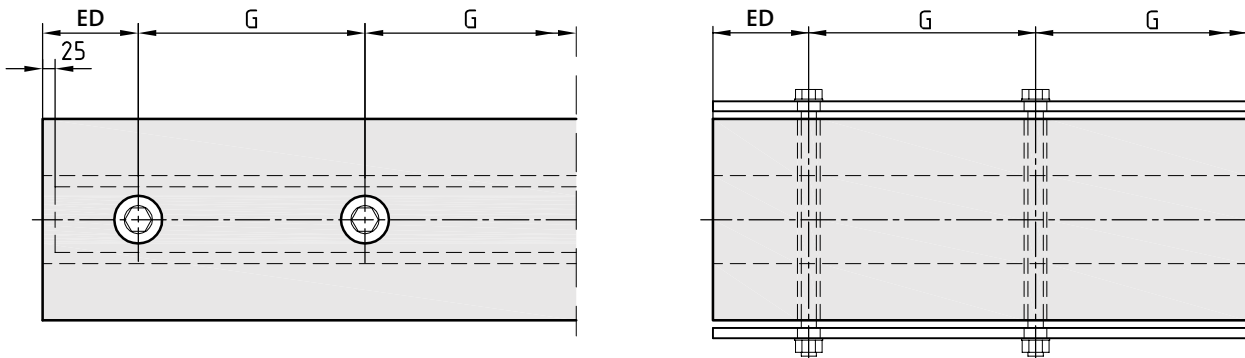

KF-A FENDERS

ShibataFenderTeam Composite Fenders KF-A are made from square rubber with a center cylindrical bore and have a vulcanized low friction front face from UHMW-PE.

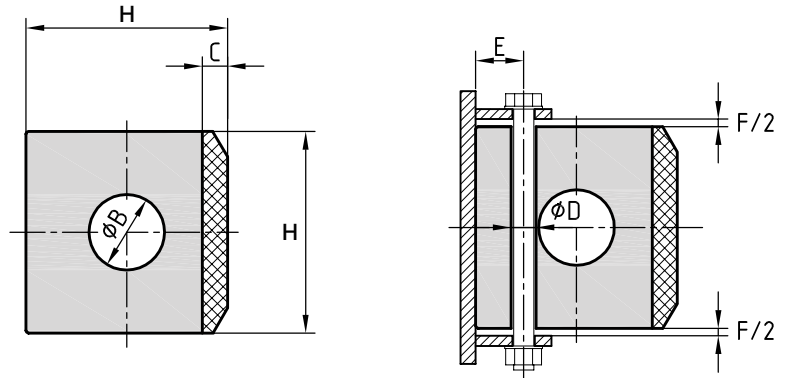

KF-A FENDER DIMENSIONS

H [mm]	B [mm]	D [mm]	E [mm]	F [mm]	C [mm]	G* [mm]	ED* [mm]	Anchors	Weight / m [kg]
100 x 100	30	18	25	10	20	200~300	90~130	M12	10.3
150 x 150	65	24	30	12	20	250~350	110~150	M16	21.5
200 x 200	75	30	45	20	25	300~400	130~180	M20	40.2
250 x 250	100	36	50	25	30	350~450	140~200	M24	60.2
300 x 300	125	36	60	30	30	350~450	140~200	M24	92.1

*Fixing Position see Page 69 acc. to ShibataFenderTeam standard manufacturing tolerances

KF-B FENDERS

ShibataFenderTeam Composite Fenders KF-B are similar to the KF-A type, with the difference that they are solid.

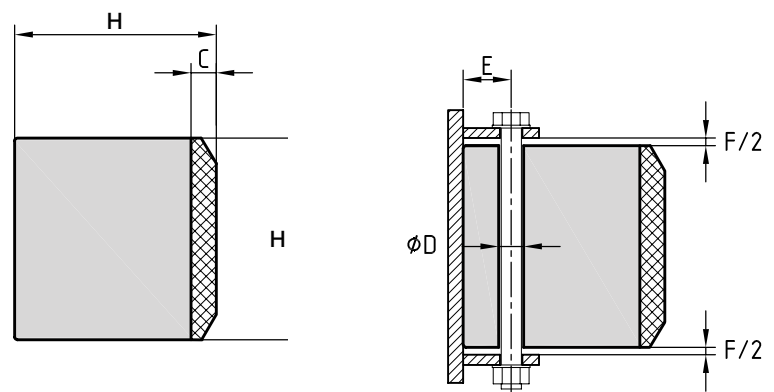

KF-B FENDER DIMENSIONS

H [mm]	D [mm]	E [mm]	F [mm]	C [mm]	G* [mm]	ED* [mm]	Anchors	Weight / m [kg]
100 x 100	18	25	10	20	200~300	90~130	M12	11.1
150 x 150	24	30	12	20	250~350	110~150	M16	27.0
200 x 200	30	45	20	25	300~400	130~180	M20	48.0
250 x 250	36	50	25	30	350~450	140~200	M24	75.0
300 x 300	36	60	30	30	350~450	140~200	M24	108.0

*Fixing Position see Page 69 acc. to ShibataFenderTeam standard manufacturing tolerances

KF-C FENDERS

ShibataFenderTeam Composite Fenders KF-C are made from trapezoidal rubber with a center cylindrical bore and have a vulcanized low friction front face from UHMW-PE.

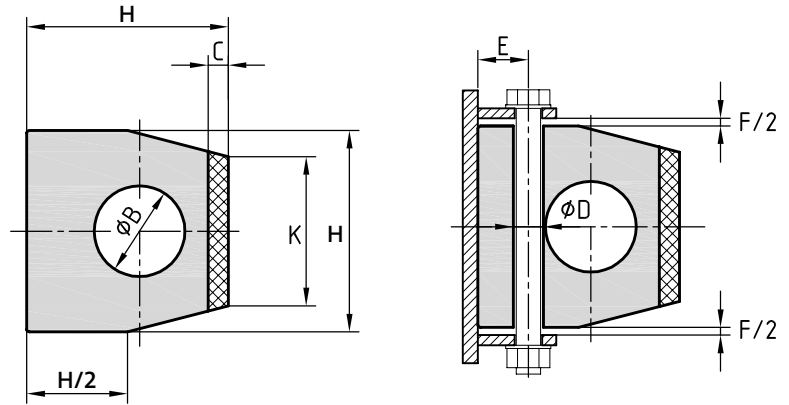

KF-C FENDER DIMENSIONS

H [mm]	B [mm]	K [mm]	D [mm]	E [mm]	F [mm]	C [mm]	G* [mm]	ED* [mm]	Anchors	Weight / m [kg]
80 x 80	42	60	18	25	6	10	200~300	90~130	M12	5.4
100 x 100	45	74	18	25	8	10	200~300	90~130	M12	8.4
120 x 120	62	88	24	30	10	12	250~350	110~150	M16	12.2
150 x 150	73	110	24	30	12	15	250~350	110~150	M16	19.7

*Fixing Position see Page 69 acc. to ShibataFenderTeam standard manufacturing tolerances

KF-D FENDERS

ShibataFenderTeam Composite Fenders KF-D are similar to the KF-C type, with the difference that they are solid.

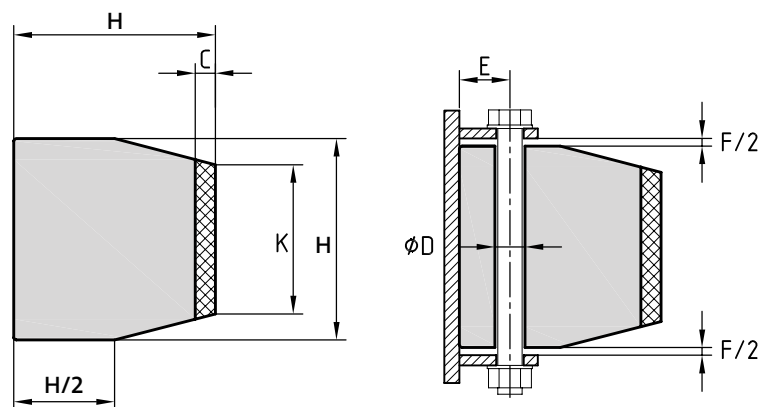

KF-D FENDER DIMENSIONS

H [mm]	K [mm]	D [mm]	E [mm]	F [mm]	C [mm]	G* [mm]	ED* [mm]	Anchors	Weight / m [kg]
80 x 80	60	18	25	6	10	200~300	90~130	M12	7.0
100 x 100	74	18	25	8	10	200~300	90~130	M12	11.0
120 x 120	88	24	30	10	12	250~350	110~150	M16	15.8
150 x 150	110	24	30	12	15	250~350	110~150	M16	24.8

*Fixing Position see Page 69 acc. to ShibataFenderTeam standard manufacturing tolerances